

ENROULEURS À MOTORISATION ÉLECTRIQUE

DIMENSIONS EC & EF+



150mm max.
50 mm min.

125mm max.
75 mm min.

MODÈLE enroul. élec.	EC 39 SX 39	EC 47 SX 47	EF+ 550 SX 47	EF+ 600 SX 53	EC 70 SX 53
Ref Profil / Émerillon	SX 39 C39	SX 47 C47	SX 47 CX47	SX 53 C600	SX 53 C600
A = ø d'étai max. (* ridoir)	ø 8 ø 10*	ø 12 ø 12,7*	ø 12 ø 14*	ø 16 ø 19*/22*	ø 19* ø 22*
B	53		53	53	52
C	175	220	220	228	
D**	98	106	103	123	127
E	162	248	263	486	404
F	62	77	82		101
G	496*	536*	770		515
J	50	50	60		-
M4	184	216	267		297
ø K	60	72	72	85	85
ø L	60	70	72	86	85
M1	122	146	146		200
M2	16		172		215
M3	160	185	324		310
N	78	100	93		-
P	98	106	103	123	127
Q	363	485	435	671	767
R	79	89	265	318	177
ø S	42	50	53		64
T	54	75	78		80
U	39	44	70		-
V	105*	104*	126		-

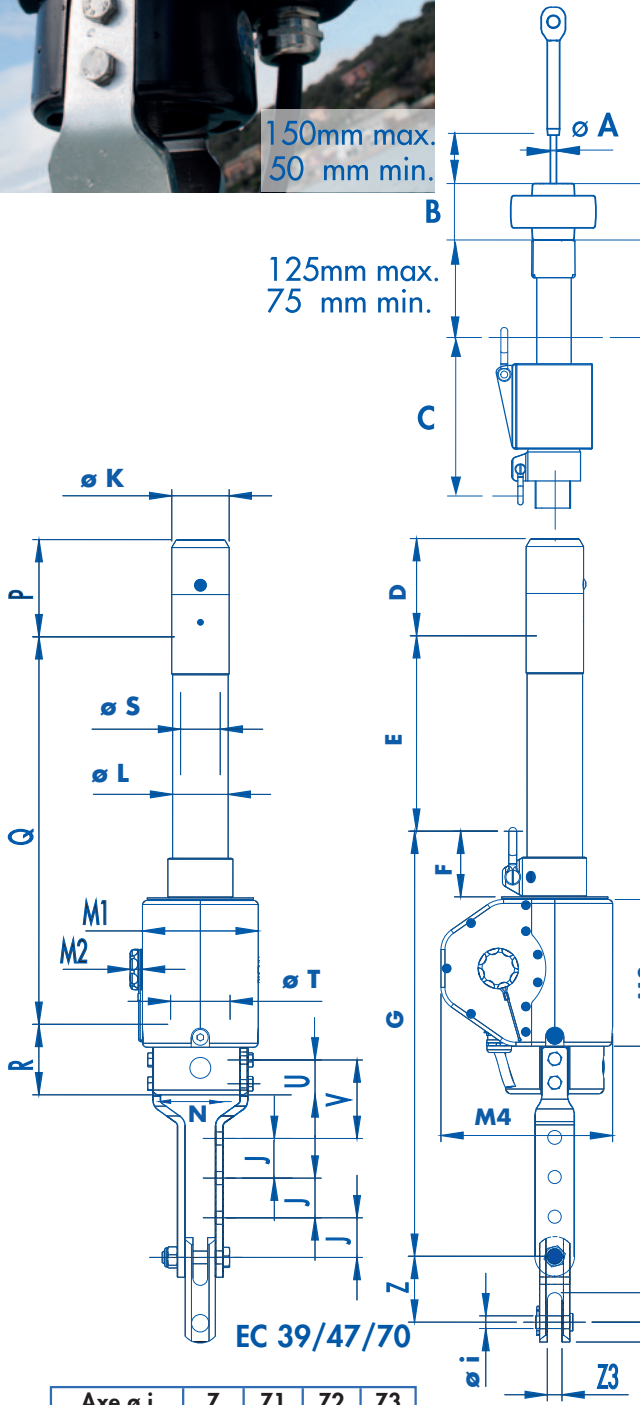

EC 39/47/70

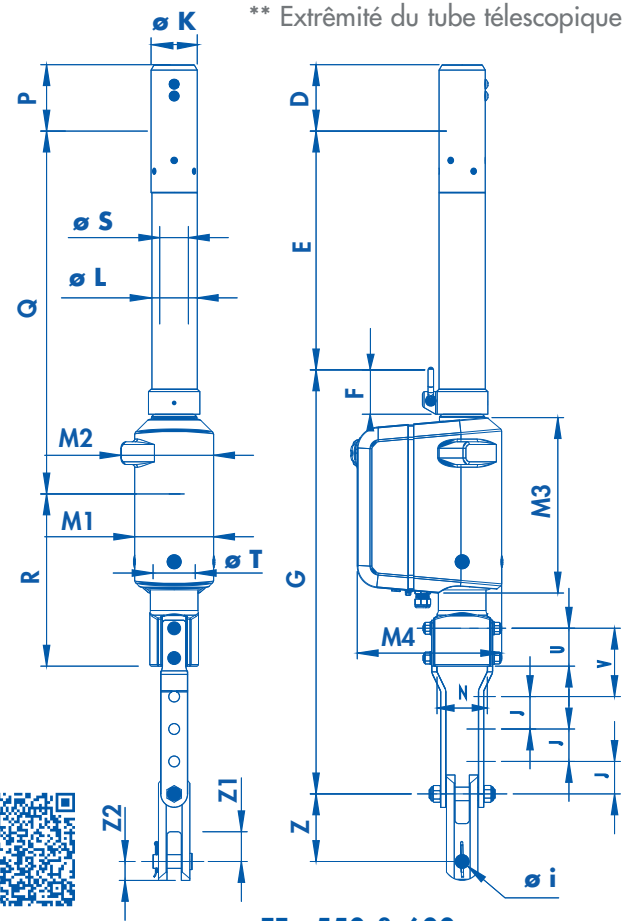

** Extrémité du tube télescopique

EF+ 550 & 600

Axe ø i	Z	Z1	Z2	Z3
12.7	77	27	19	13
16	82	28	25	18.5
19	94	42	29	20,5
22	105	36.5	32.5	22.5
25	125	55	35	26.5
28	140	50	39	31
32	165	75	42	33
32 (EC70)	165	91	42	33



> Notices EC/EF+