

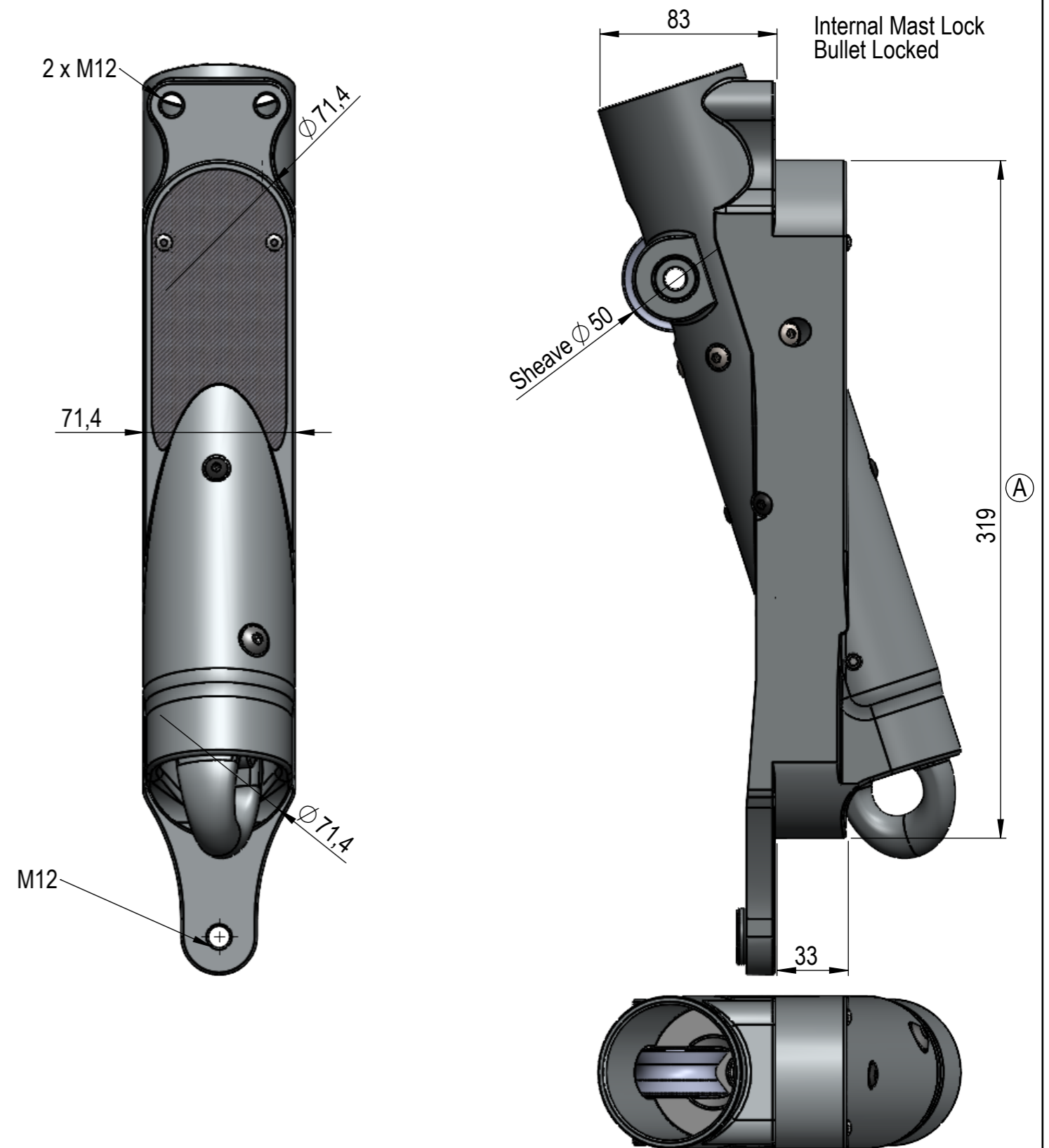

Poids Calc: 6838.96 g

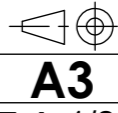

REV.	DATE	AUTEUR	APPROUVE	DESCRIPTION
B	18/03/2021	de		changement cotation passage drisse
A	22/07/2020	AB	DE	Changement cote hauteur 317 --> 319

INTERNAL LOCK 15T SWL 18° BEAR 33			 <b>A3</b> Ech: 1/2.5	 FACNOR S.A. Parc d'Activités - B.P. 222 F-50550 SAINT-VAAST-LA-HOUGUE tel. +33 (0)2 33 88 50 22 fax. +33 (0)2 33 23 14 27
Date: 16/09/2016	Tol. Gén.: +/-0.15	Etude: 2016MF0		
Auteur: MFéron	Matière: APX4	88961500072	Ce plan est la propriété intellectuelle de FACNOR SA. Il ne peut être divulgué à des tiers sans notre autorisation écrite, ni servir à d'autres fabrications.	
Indice: (B)	Finition: Poli manuel			