

Internal Mast Lock
Bullet approaching

SS body equipped: 4.0Kg

COUPE A-A 1 : 2

SS & TA6V: 0.82Kg

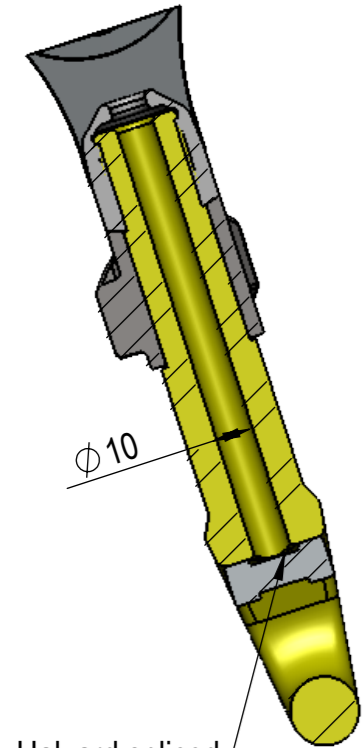

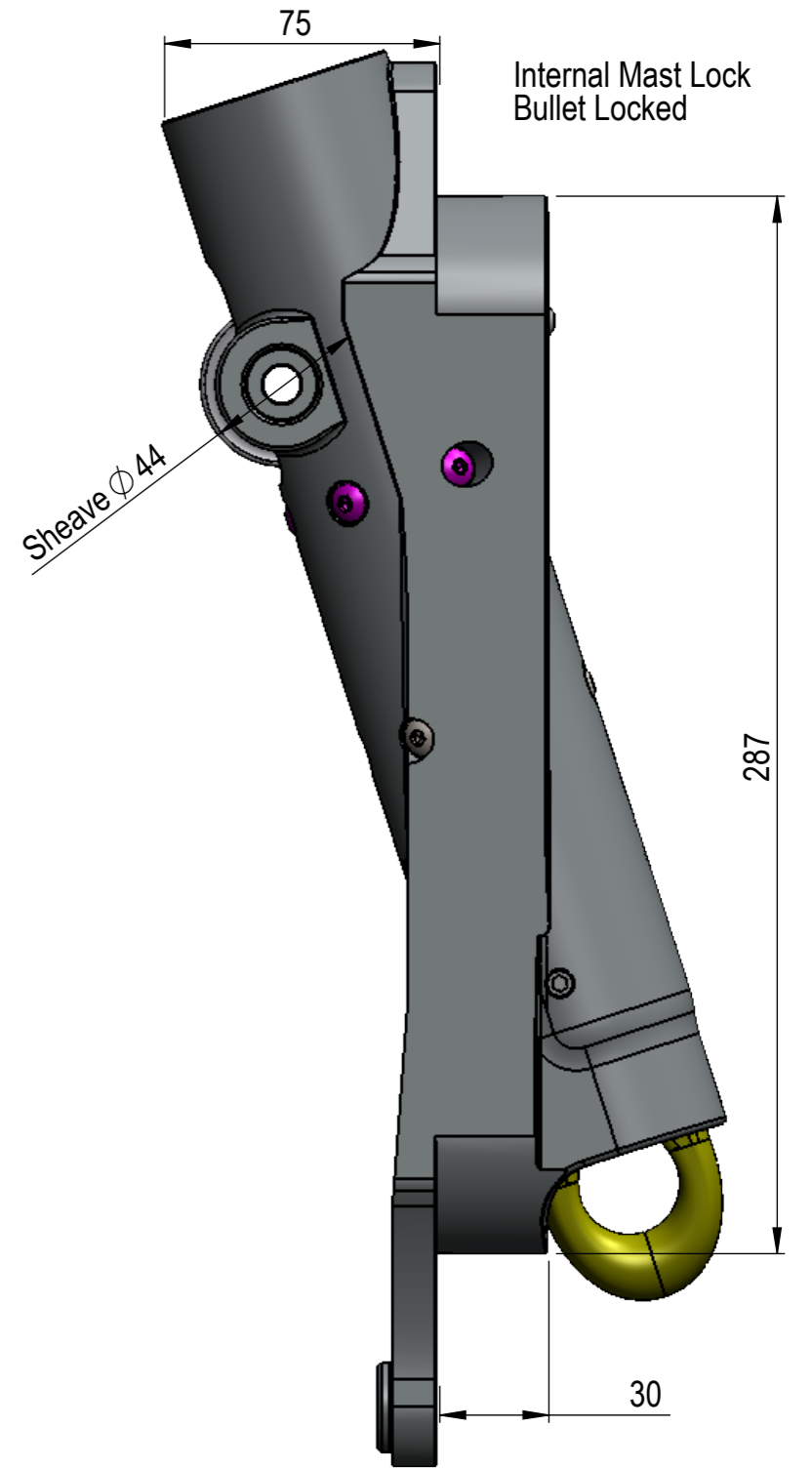
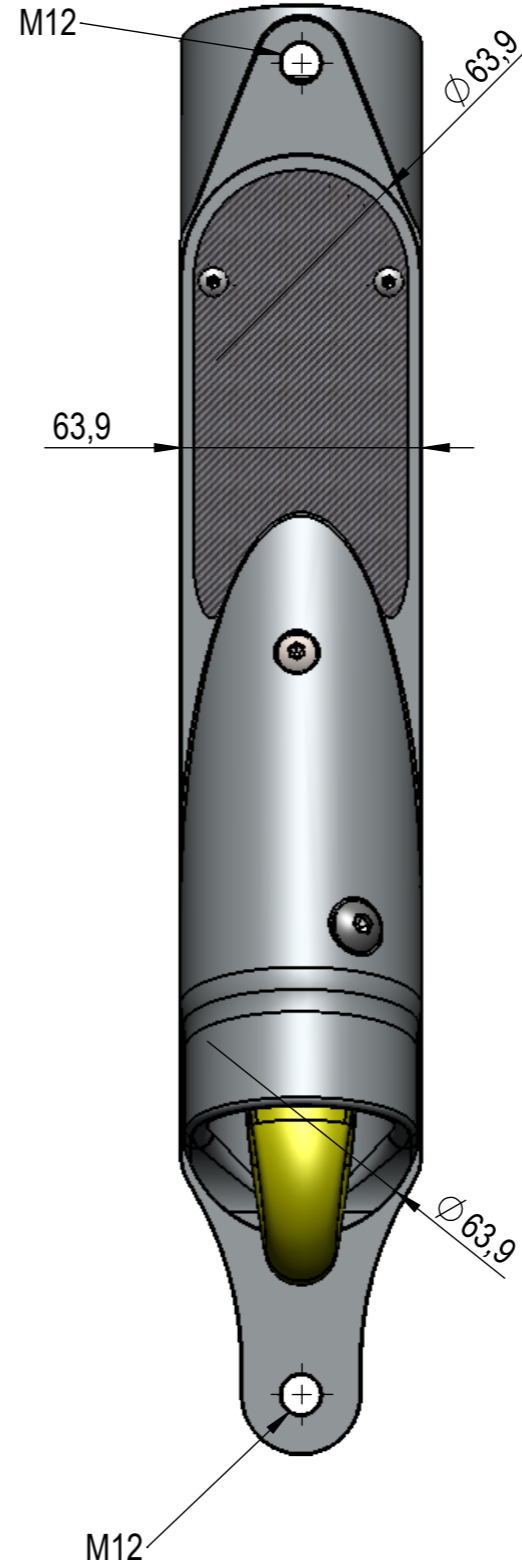
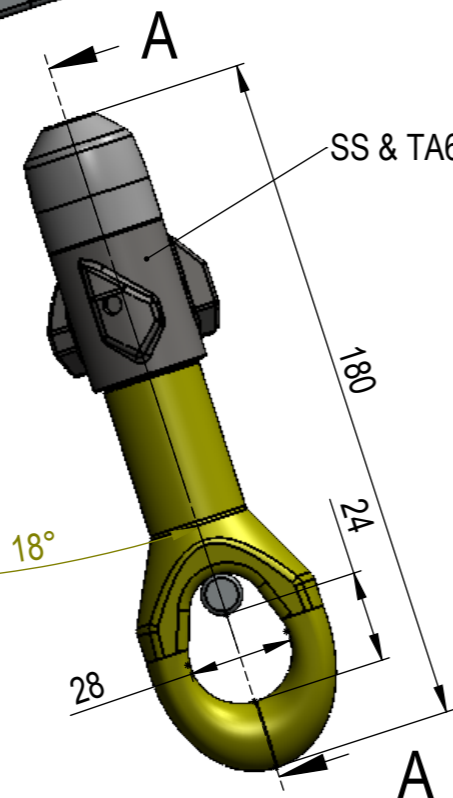

Halyard spliced
with dogbone

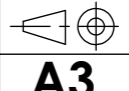

Poids Calc: 5016.69 g

MAXIMUM WORKING
LOAD : 12T
BREAKING LOAD : 24T

REV.	DATE	AUTEUR	APPROUVE	DESCRIPTION
A	31/05/2021	DE		NEW LASHING EYE, ADDED INFORMATIONS HALYARD AND LOADS
				INTERNAL LOCK 12T MWL 18° BEAR 30
				 A3 Ech: 1/2
Date: 16/09/2016		Tol. Gén.: +/-0.15		 FACNOR S.A. Parc d'Activités - B.P. 222 F-50550 SAINT-VAAST-LA-HOUGUE tel. +33 (0)2 33 88 50 22 fax. +33 (0)2 33 23 14 27
Auteur: MFéron		Matière:		
Indice: A		Finition:		
Etude: 2016MF0				Ce plan est la propriété intellectuelle de FACNOR SA. Il ne peut être divulgué à des tiers sans notre autorisation écrite, ni servir à d'autres fabrications.