

Swivel Only:
1.05 Kg

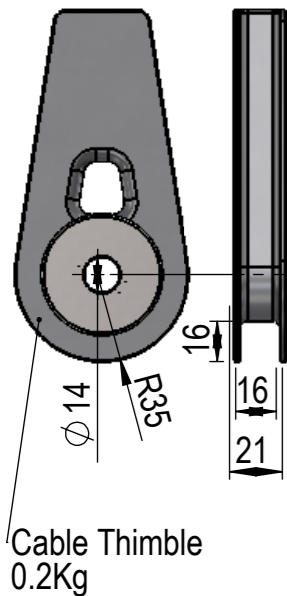

Cable Thimble
0.2Kg

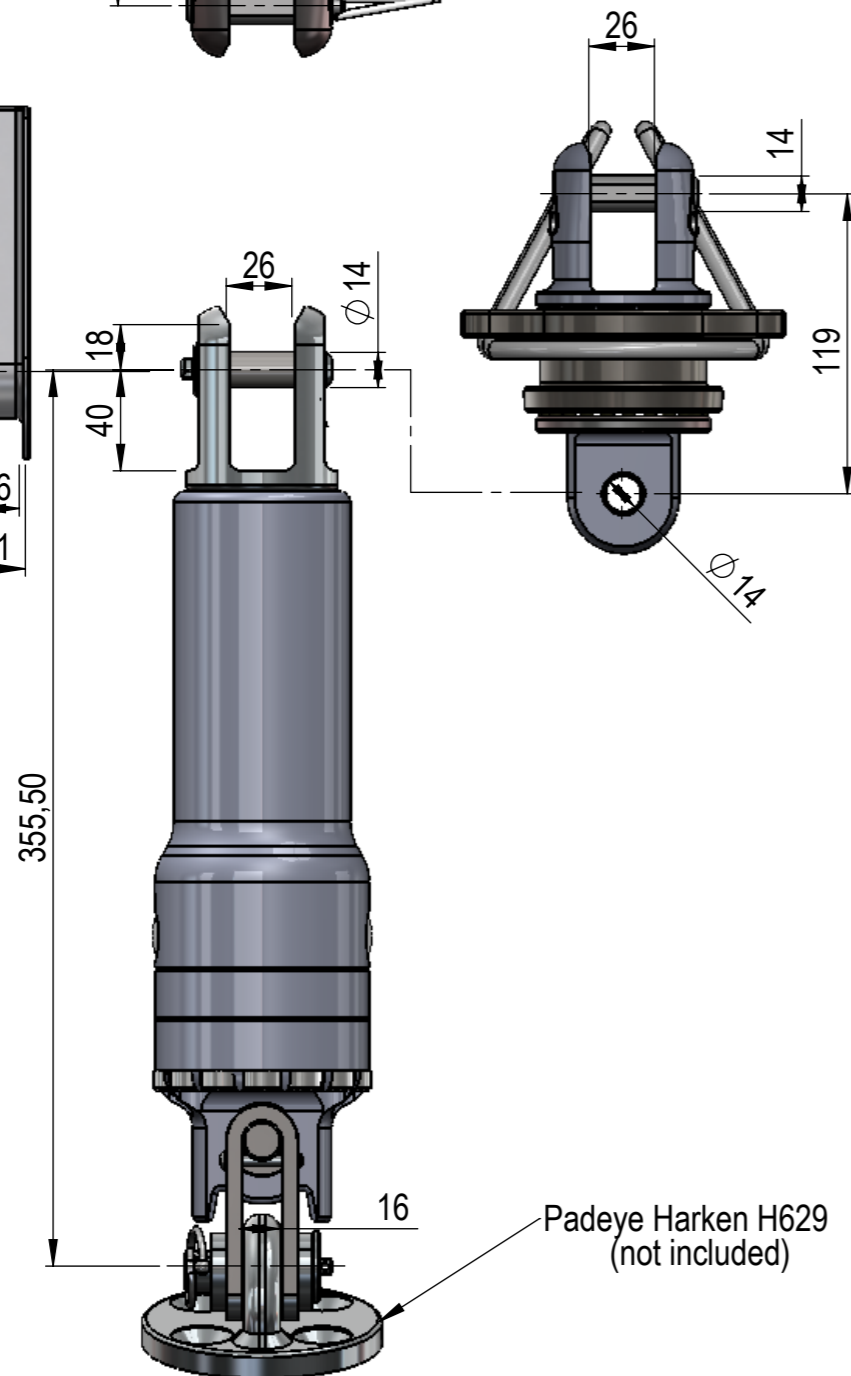

Padeye Harken H629
(not included)

Fast Thimble
1.15Kg

Torlon Balls

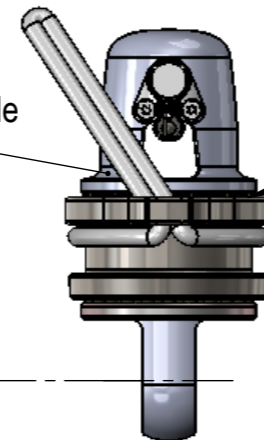

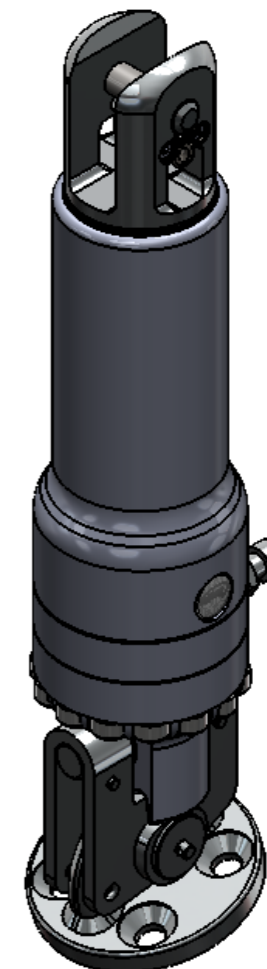

Moteur hydraulique 50cc ^(A)
vitesse 120rpm / 10LxMn
pression optimale 125 bars
pression maxi 140 bars



Hydraulic
Furler Only:
5.9 Kg

Poids Calc: 1296.06 g

REV.	DATE	AUTEUR	APPROUVE	DESCRIPTION
A	29/04/2016	PL		Ajouté info moteur
FXH 7 000 & Equipment STANDARD				 A3 Ech: 1:5
Date: 22/04/2016	Tol. Gén.: +/-0.15	Etude: 22042016MF01		 FACNOR S.A. Parc d'Activités - B.P. 222 F-50550 SAINT-VAAST-LA-HOUGUE tel. +33 (0)2 33 88 50 22 fax. +33 (0)2 33 23 14 27
Auteur: MFéron	Matière: --	Usiné:		
Indice: (A)	Finition: --	Repris: PoliM:		
				Ce plan est la propriété intellectuelle de FACNOR SA. Il ne peut être divulgué à des tiers sans notre autorisation écrite, ni servir à d'autres fabrications.